

User manual

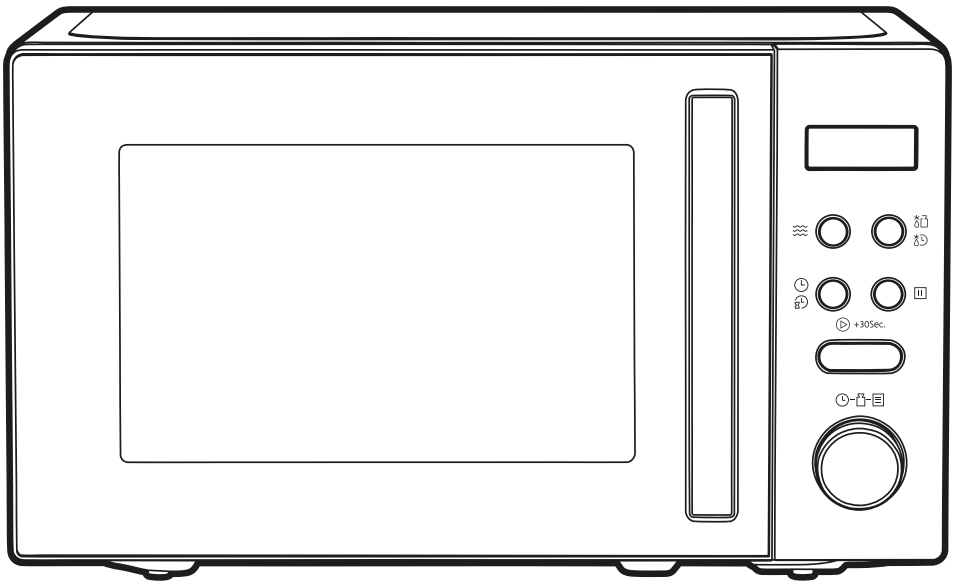

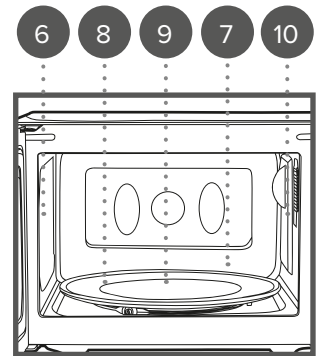

Microwave

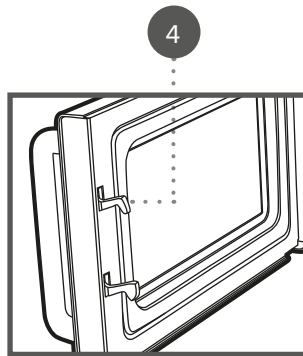
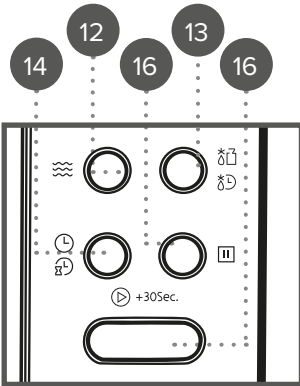
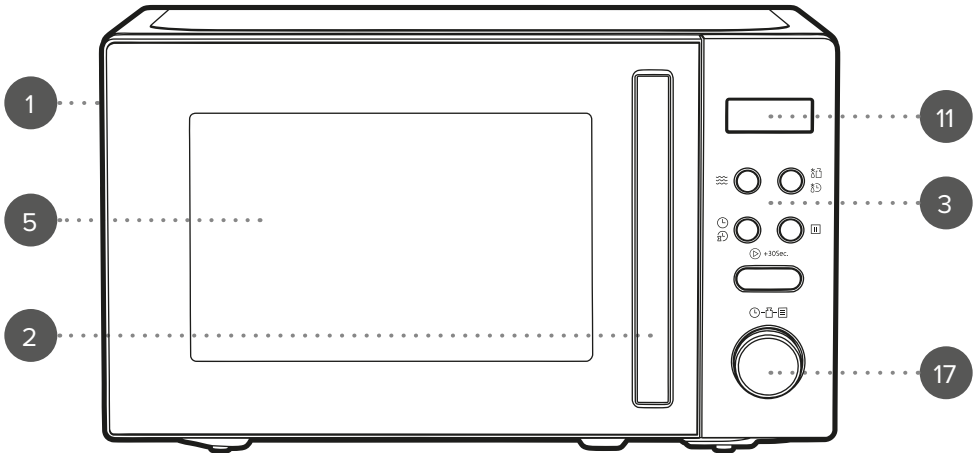

Description of parts



1. Microwave main unit
2. Door handle
3. Control panel
4. Door safety interlock
5. Viewing window
6. Oven cavity
7. Glass turntable
8. Turntable ring
9. Turntable shaft

10. Waveguide cover
11. LED display
12. Microwave button ()
13. Defrost button ()
14. Timer/clock button ()
15. Stop/clear button ()
16. Start/confirm/+30s button ()
17. Control dial

Please retain instructions for future reference.



WARNING – READ BEFORE USE: If the door or door seals are damaged, the appliance must not be operated until it has been repaired by a competent person. It is hazardous for anyone other than a competent person to carry out any service or repair operation that involves the removal of a cover which gives protection against exposure to microwave energy. Liquids and other foods must not be heated in sealed containers since they are liable to explode. The heating of beverages in the appliance can result in delayed eruptive boiling, therefore extreme care must be taken when handling the container. Always allow beverages to stand for at least 20 seconds before handling. If necessary, stir during heating. Always stir after heating.

SAFETY INSTRUCTIONS

- When using electrical appliances, basic safety precautions should always be followed.
- Check that the voltage indicated on the rating plate corresponds with that of the local network before connecting the appliance to the mains power supply.
- This appliance can be used by children aged from 8 years and above and persons with reduced physical, sensory or mental capabilities and knowledge, if they have been supervised/instructed and understand the hazards involved.
- Children shall not play with the appliance.
- Children should not perform cleaning or user maintenance, unless they are older than 8 and supervised.
- This appliance is not a toy.
- If the power supply cord, plug or any part of the appliance is malfunctioning or if it has been dropped or damaged, cease using the product immediately to avoid potential injury.
- This appliance contains no user serviceable parts, only a qualified electrician should carry out repairs. Improper repairs may place the user at risk of harm.
- Keep the appliance and its power supply cord out of the reach of children.
- Keep the appliance out of the reach of children when it is switched on or cooling down.
- Keep the appliance and its power supply cord away from heat or sharp edges that could cause damage.
- Keep the power supply cord away from any parts of the appliance that may become hot during use.
- Keep the appliance away from other heat emitting appliances.
- Do not allow the power supply cord to hang over worktops, touch hot surfaces or become twisted.

- Do not immerse the electrical components of the appliance in water or any other liquid.
- Do not operate the appliance with wet hands or if any connections are wet.
- If this appliance falls or accidentally becomes immersed in water, unplug it from the wall outlet immediately. Do not reach into the water.
- Do not leave the appliance unattended whilst connected to the mains power supply.
- Do not remove the appliance from the mains power supply by pulling the cord; switch it off and remove the plug by hand.
- Do not pull or carry the appliance by its power supply cord.
- Do not use the appliance for anything other than its intended use.
- Do not use any accessories other than those supplied.
- Do not use this appliance outdoors.
- Do not store the appliance in direct sunlight or in high humidity conditions.
- Do not move the appliance whilst it is in use.
- Always unplug the appliance after use and allow it to cool fully before any cleaning, user maintenance or storing away.
- Always use the appliance on a stable, heat-resistant surface, at a height that is comfortable for the user.
- This appliance should not be operated by means of an external timer or separate remote control system.
- Use of an extension cord with the appliance is not recommended.
- This appliance is intended for domestic use only. It should not be used for commercial purposes.



CAUTION: Hot surface – do not touch hot sections or heating components of the appliance.



WARNING: Keep the appliance away from flammable materials.

Dos and don'ts

DO:

Switch off the appliance and disconnect it from the mains power supply before changing or fitting attachments.

DON'T:

Use attachments if they are loose, damaged or broken.

Product group definition

This product is a Group 2 Class B appliance.

Group 2 ISM equipment: Group 2 contains all ISM equipment in which radio-frequency energy is intentionally generated and/or used in the form of electromagnetic radiation for the treatment of material, and EDM and arc welding equipment.

Class B equipment is equipment suitable for use in domestic establishments and in establishments directly connected to a low voltage power supply network which supplies buildings used for domestic purposes.

Installing the microwave

The appliance is intended to be used on the countertop only; it should not be placed in a cabinet.

The appliance should be installed away from sources of heat and humidity.

To ensure sufficient ventilation, the appliance should be placed with its back against a wall, with 20 cm of free space between its sides and the wall and 30 cm of free space above it. The appliance should be at least 85 cm above floor level on a flat, stable, heat-resistant surface.

The appliance should be at least 5 m away from any TVs, radios or other appliances with antennas, as picture disturbance or noise may occur.

The appliance must be positioned so that the plug is accessible.

Do not remove the legs from the bottom of the appliance.

Blocking the intake and/or outlet openings can damage the appliance.

Only use utensils that are suitable for use in microwave ovens.

Care and maintenance

Switch off and unplug the microwave from the mains power supply and allow it to cool fully before attempting any cleaning or maintenance.

STEP 1: Wipe the exterior of the microwave with a soft, damp cloth and dry thoroughly.

STEP 2: Using a soft, damp cloth, wipe the microwave door and window, door seals and control panel to remove any spill or spatter.

STEP 3: Wipe the interior surfaces, including the waveguide cover, with a soft, damp cloth, to remove any built-up grease, as this may begin to smoke or catch fire.

Do not use harsh or abrasive cleaning detergents or scourers to clean the microwave or its accessories, as this could cause damage.



NOTE: The microwave and accessories should be cleaned after each use.



WARNING: Do not remove the waveguide cover. Failure to maintain the microwave in a clean condition could lead to deterioration of the surface that could adversely affect the life of the microwave and possibly result in a hazardous situation.

Instructions for use

Before first use

Clean the microwave following the instructions in the section entitled '**Care and maintenance**'.

Place the microwave onto a flat, stable, heat-resistant surface at a height that is comfortable for the user.

Ensure the turntable ring is installed in the centre of the microwave and place the glass turntable on top, ensuring the grooves on the underside of the glass turntable align with the turntable shaft. Ensure the glass turntable is in place and moves freely before use.



NOTE: When using the microwave for the first time, a slight smoke or odour may be emitted. This is normal and will soon subside. Allow for sufficient ventilation around the microwave. It is advised to heat a small cup of water in the microwave before first use as this will help to remove residue from manufacturing inside the cavity and will prevent the initial smoke or odour from affecting the taste of the food. **ALWAYS ALLOW BEVERAGES/LIQUIDS TO STAND FOR AT LEAST 20 SECONDS BEFORE HANDLING TO AVOID ERUPTIVE BOILING.**



CAUTION: The glass turntable must not be restricted during use; pay extra attention when cooking food that expands, such as popcorn, as this may obstruct the turntable movement.

Using the microwave

STEP 1: Plug in and switch on the microwave at the mains power supply.

STEP 2: Place the food to be microwaved onto the glass turntable and close the door. Make sure to use microwave safe plates or containers.

Function	Use	Suggested uses
Microwave	Quickly reheats/cooks meals.	Soup, rice, microwave meals, leftovers.
Speedy cooking	Sets the microwave at 100% power for 30 seconds.	Popcorn, beverages, rice.
Defrost	Defrosts frozen food.	All food types.
Multi-stage cooking	Sets up two cooking functions for consecutive cooking, e.g. – defrost then microwave.	Meat, vegetables, chips.

Function	Use	Suggested uses
Auto menu	8 preset cooking functions available – reheat, fresh vegetables, fish, meat, pasta, potato, frozen pizza, soup.	Refer to the cooking chart in the section entitled ' Auto menu chart '.



CAUTION: It is recommended to wear gloves when removing cooked foods from the microwave; avoid touching the heating element on the roof of the cooking cavity.

Power level

5 power levels are available.

Level	Microwave power output	Display
1	10%	P10
2	30%	P30
3	50%	P50
4	80%	P80
5	100%	P100

Setting the time

STEP 1: Press ' \odot ' once. The LED display will show '**0:00**'.

STEP 2: Turn the control dial to set the hour. The time should be between 0–23 hours.

STEP 3: Press ' \odot ' to confirm the hour selection.

STEP 4: Turn the control dial to set the minute. The time should be between 0–59 minutes.

STEP 5: Press ' \odot ' to confirm the minute selection and set the time.



NOTE: The time needs to be set before using the microwave. To reset the clock, repeat steps 1–5. If ' \square ' is pressed, or there is no activity within approx. 5 minutes, the microwave will beep once and return to standby mode. When the microwave is in a cooking state, press ' \odot ' once to display the clock for approx. 3 seconds.

Setting the kitchen timer

STEP 1: Press ' \odot ' twice. The LED display will show '**0:00**'.

STEP 2: Turn the control dial to set the desired time. The maximum time is '**95:00**'.

STEP 3: Press ' \triangleright ' to confirm and start the timer.



NOTE: Other programmes cannot be set whilst setting the kitchen timer.

Microwave cooking

STEP 1: Press '☞' once. The LED display will show 'P100'.

STEP 2: Set the power level by pressing '☞' or by turning the control dial. Press '▶' to confirm.

STEP 3: Turn the control dial to adjust the cooking time.

STEP 4: Press '▶' to start cooking.



NOTE: When the microwave is in a cooking state, press '☞' once to display the power level for approx. 3 seconds.

Speedy cooking

Two speedy cooking methods are available:

Using '▶' (START/CONFIRM/+30S)

STEP 1: In standby mode, press '▶' to start cooking with 100% power for 30 seconds.

Using the control dial

STEP 1: In standby mode, turn the control dial anticlockwise to set the microwave cooking time with 100% power.

STEP 2: Press '▶' to start cooking.



NOTE: The time can be adjusted in 30 second increments by pressing '▶' whilst cooking.

Defrost by weight

STEP 1: Press '☞ ☞' once. The LED screen will display 'dEF1'.

STEP 2: Turn the control dial to set the weight of food between 100–2000 g.

STEP 3: Press '▶' to start defrosting.

STEP 4: Once defrosting has finished, the microwave will beep five times.



NOTE: When 30% of the time has passed, the microwave will beep twice to signal that the food needs turning. If food isn't turned, the microwave will continue defrosting.

Defrost by time

STEP 1: Press '☞ ☞' twice. The LED screen will display 'dEF2'.

STEP 2: Turn the control dial to set the time. The maximum time is '95:00'.

STEP 3: Press '▶' to start defrosting.

STEP 4: Once defrosting has finished, the microwave will beep five times.



NOTE: When 50% of the time has passed, the microwave will beep twice to signal that the food needs turning. If food isn't turned, the microwave will continue defrosting.

Multi-stage cooking

Two cooking stages can be set in order to achieve the best cooking results.

Example: Defrost food for 5 minutes then cook with 80% power for 7 minutes.

STEP 1: Press '❄️ ⏸️' twice. The LED screen will display 'dEF2'.

STEP 2: Turn the control dial to set the defrost time to 5 minutes.

STEP 3: Press '🌊' once. The LED display will show 'P100'.

STEP 4: Set the power level to 80% by pressing '🌊' or by turning the control dial to 'P80'. Press '▶️' to confirm.

STEP 5: Turn the control dial to set the cooking time to 7 minutes.

STEP 6: Press '▶️' to start defrosting. Cooking will commence once defrosting is complete.



NOTE: If defrost is selected, it will automatically be the first step in the multi-stage cooking. The auto menu function cannot be used during multi-stage cooking.

Auto menu

STEP 1: In standby mode, turn the control dial in a clockwise direction. The LED display will show 'A-1'. Use the control dial to cycle through the 8 preset options.

STEP 2: Press '▶️' to confirm.

STEP 3: Turn the control dial to set the weight of the food.

STEP 4: Press '▶️' to start cooking.

Auto menu chart

Menu	Weight options	Display	Time (mins)	Power
A-1 Reheat	200 g	200	2:10	P100
	400 g	400	4:10	
	600 g	600	6:00	
A-2 Fresh vegetables	200 g	200	3:30	P100
	300 g	300	5:30	
	400 g	400	7:00	
A-3 Fish	250 g	250	4:00	P80
	350 g	350	5:00	
	450 g	450	7:00	
A-4 Meat	250 g	250	4:00	P100
	350 g	350	5:30	
	450 g	450	6:30	

Menu	Weight options	Display	Time (mins)	Power
A-5 Pasta	50 g (with 450 ml cold water)	50	18:00	P80
	100 g (with 800 ml cold water)	100	21:00	
A-6 Potato	200 g	200	5:00	P100
	400 g	400	9:00	
	600 g	600	11:00	
A-7 Frozen pizza	200 g	200	3:00	
	400 g	400	5:00	
A-8 Soup	200 ml	200	2:00	

Child lock function

This feature is ideal for locking the control panel when cleaning or to prevent children from using the microwave unsupervised. All buttons are rendered inoperable when the child lock function is used.

STEP 1: In standby mode, press and hold '☐' for approx. 3 seconds to lock the microwave. A long beep will sound to signal that the child lock function is activated, and the LED screen will display a locked icon.

STEP 2: To unlock the microwave, press and hold '☐' for approx. 3 seconds. A long beep will sound to signal that the child lock function is deactivated and the LED screen will return to standby mode.

Storage

Check that the microwave is cool, clean and dry before storing in a cool, dry place. Never wrap the cord tightly around the microwave; wrap it loosely to avoid causing damage.

Specifications

Product code: EK6444

Capacity: 20 L

Input: 230–240 V ~ 50 Hz

Rated input power: 1200–1270 W

Rated output power: 750–800 W

Frequency: 2450 MHz

SERVICING SAFEGUARDS FOR QUALIFIED ELECTRICIANS ONLY

CAUTION: MICROWAVE RADIATION.

1. The high voltage capacitor remains charged after disconnection; short the negative terminal of the H.V capacitor to the oven chassis using a screwdriver to discharge before touching.

2. During servicing, the below listed parts are liable to be removed and give access to potentials above 250 V to earth.

- Magnetron
- High voltage transformer
- High voltage capacitor
- High voltage diode
- High voltage fuse

3. The following conditions may cause undue microwave exposure during servicing:

- Improper fitting of magnetron.
- Improper matching of door interlock, door hinge and door.
- Improper fitting of switch support.
- The door, door seal or enclosure has been damaged.



Disposal of Waste Batteries and Electrical and Electronic Equipment



This symbol on the product, its batteries or its packaging means that this product and any batteries it contains must not be disposed of with household waste. Instead, it is the user's responsibility to hand this over to an applicable collection point for the recycling of batteries and electrical and electronic equipment. This separate collection and recycling will help to conserve natural resources and prevent potential negative consequences for human health and the environment due to the possible presence of hazardous substances in batteries and electrical and electronic equipment, which could be caused by inappropriate disposal. Some retailers provide take-back services which allow the user to return exhausted equipment for appropriate disposal. **It is the user's responsibility to delete any data on electrical and electronic equipment prior to disposal.** For more information about where to drop batteries, electrical and electronic waste off, please contact the local city/municipality office, household waste disposal service, or the retailer.

Manufactured by:
Ultimate Products UK Ltd.,
Victoria Street, Manchester OL9 0DD. **UK.**
Ultimate Products Europe Ltd.,
19 Baggot Street Lower, Dublin D02 X658. **ROI.**

MADE IN CHINA.

CD171024/MD000000/V1